

DMS-50

DUAL MOTORIZED TOP DOWN ROLLER SHADE WITH MOTOR SYSTEM

FEATURES:

- Contemporary and compact roller shade system
- Fabric wrapped fascia available
- Extendable idle
- Available as coupled shade

BENEFITS:

- Compact and strong
- Smooth operation
- Simple installation
- Available with AC, DC or Battery Motors
- Extendable idle
- Short bracket
- Small light gaps

SYSTEM INDEX

1. MOTOR

2. TUBE

- A. 45mm Tube
- B. 49mm Tube

3. SLIMLINE DUAL BRACKET

Available in White, Gray and Black

4. SQUARE DUAL BRACKET

Available in White, Gray and Black

5. IDLER

Available in White, Gray and Black

6. HEMBAR

- A. Sealed Hembar
- B. Exposed w/End Caps
- C. Fabric Wrapped w/End Caps

7. OPTIONAL FASCIA SYSTEM

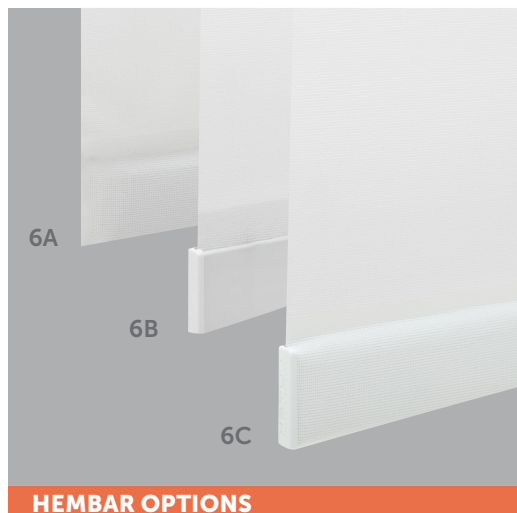
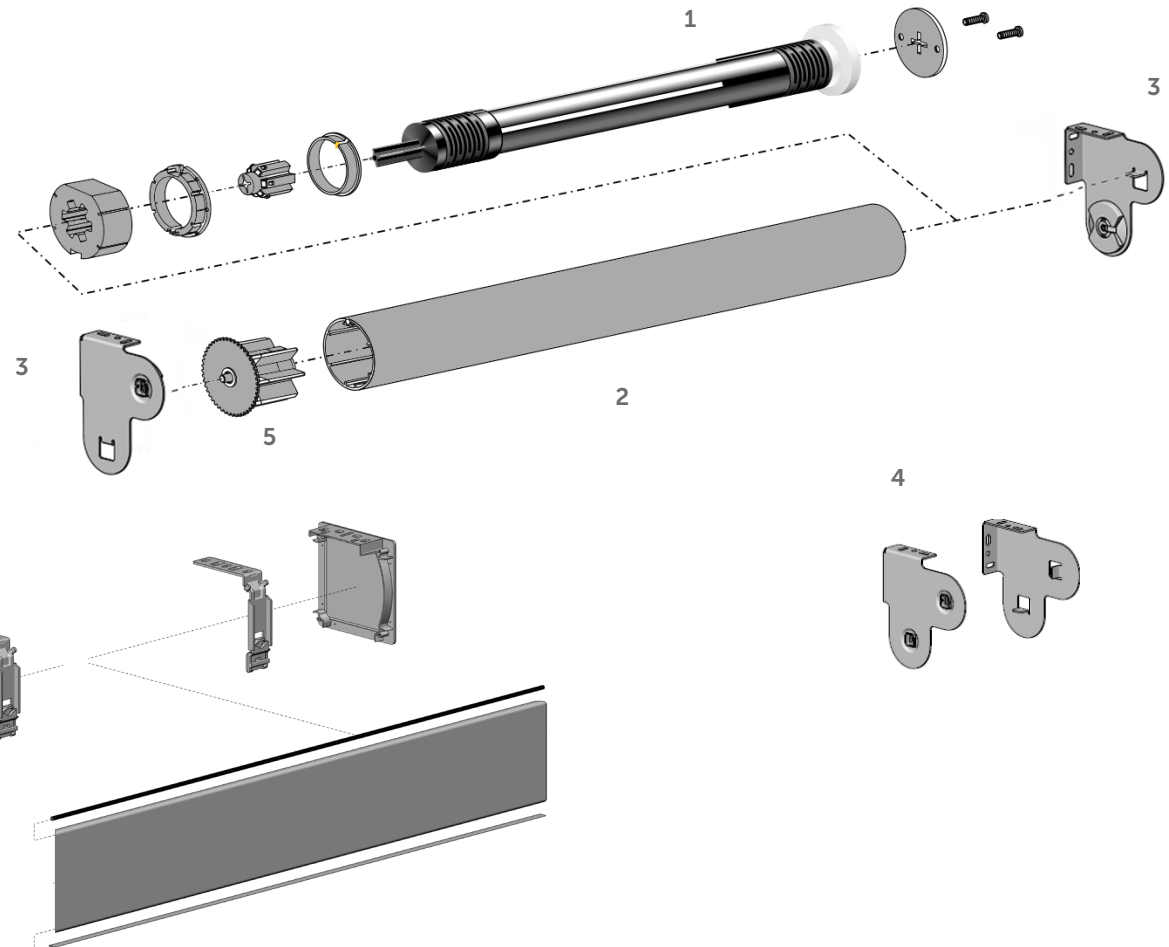

HEMBAR OPTIONS

DMS-50

DUAL MOTORIZED TOP DOWN ROLLER SHADE WITH MOTOR SYSTEM

SHADE DEDUCTIONS

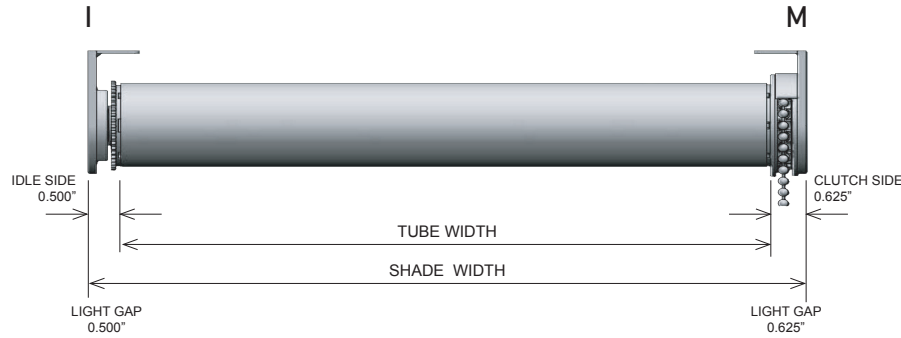

COUPLED SHADE DEDUCTIONS

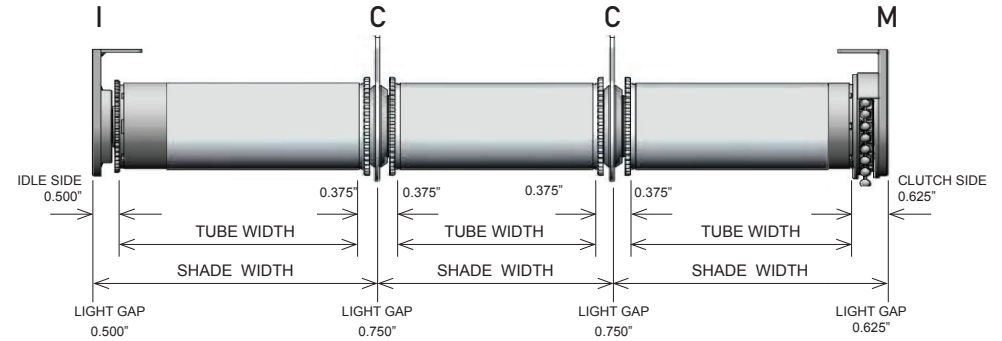

DRIVE	BRACKETS	IDLE SIDE	COUPLER SIDE	CLUTCH SIDE	OVERALL DEDUCTION
M-I	WITH FASCIA END CAPS	0.625" (15.9mm)		0.750" (19.1mm)	1.375" (34.9mm)
	WITHOUT FASCIA END CAPS	0.500" (12.7mm)		0.625" (15.9mm)	1.125" (28.6mm)
I-C	WITH FASCIA END CAPS	0.625" (15.9mm)	0.375" (9.5mm)		1.00" (25.4mm)
	WITHOUT FASCIA END CAPS	0.500" (12.7mm)	0.375" (9.5mm)		0.875" (22.2mm)
C-C	WITH FASCIA END CAPS		0.750" (19.1mm)		0.750" (19.1mm)
	WITHOUT FASCIA END CAPS		0.750" (19.1mm)		0.750" (19.1mm)
M-C	WITH FASCIA END CAPS		0.375" (9.5mm)	0.750" (19.1mm)	1.125" (28.6mm)
	WITHOUT FASCIA END CAPS		0.375" (9.5mm)	0.625" (15.9mm)	1.00" (25.4mm)

DMS-50 SYSTEM CAPACITY

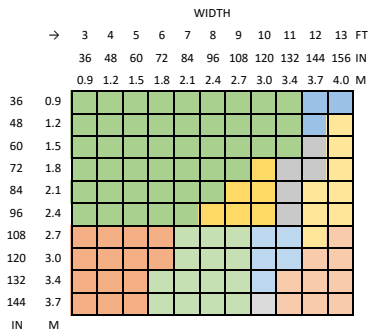

Parameters
 Fabric Weight (oz/sq yd): 13.30
 Fabric Thickness (in): 0.02
 Hembar Weight (oz/ft): 2.75

CONTROL	BRACKET	TUBE
1.1 Nm Motor	Slimline Bracket	45mm
1.1 Nm Motor	Slimline Bracket	49mm
2 Nm Motor	Slimline Bracket	45mm
2 Nm Motor	Slimline Bracket	49mm
1.1 Nm Motor	Square Bracket	45mm
1.1 Nm Motor	Square Bracket	45mm/49mm Square Coupler
2 Nm Motor	Square Bracket	45mm
2 Nm Motor	Square Bracket	49mm
2 Nm Motor	Square Bracket	45mm/49mm Square Coupler
3 Nm Motor	Square Bracket	49mm
3 Nm Motor	Square Bracket	45mm/49mm Square Coupler
4 Nm Motor	Square Bracket	45mm/49mm Square Coupler
6 Nm Motor	Square Bracket	45mm/49mm Square Coupler

Outside Specifications
 *For optimal performance shades need to maintain 4:1 ratio of length to width. Shades can be outside this ratio however shade performance could be impacted

**Exceeding these values may cause fabric tracking issues

***Coupled shades available for larger widths

MAX ROLL

