

# ML-40

## MANUAL TOP DOWN ROLLER SHADE WITH CLUTCH SYSTEM

### FEATURES:

- Contemporary and compact roller shade system
- Field upgradable to motorization MS - 40
- Fabric wrapped fascia available
- Extendable idle
- Available as coupled shade

### BENEFITS:

- Compact and strong
- Smooth operation
- Simple installation
- Can be converted to motorized with AC, DC or Battery Motors
- Extendable idle
- Short bracket
- Small light gaps
- Available as crank operation

### SYSTEM INDEX

#### 1. CLUTCH

Available in White, Gray and Black

#### 2. TUBE

- A. 45mm Tube
- B. 49mm Tube

#### 3. CLUTCH BRACKET

Available in White, Gray and Black

#### 4. IDLE BRACKET

Available in White, Gray and Black

#### 5. IDLER

Available in White, Gray and Black

#### 6. HEMBAR

- A. Sealed Hembar
- B. Exposed w/End Caps
- C. Fabric Wrapped w/End Caps

#### 7. CHAIN HOLD DOWN

Available in White, Gray and Black

#### 8. OPTIONAL FASCIA SYSTEM

#### 9. CHAIN

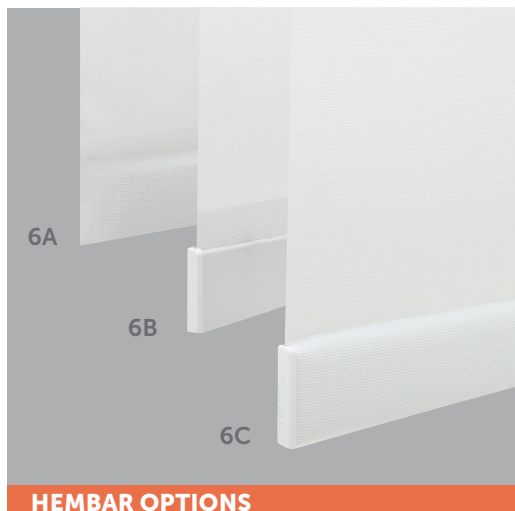
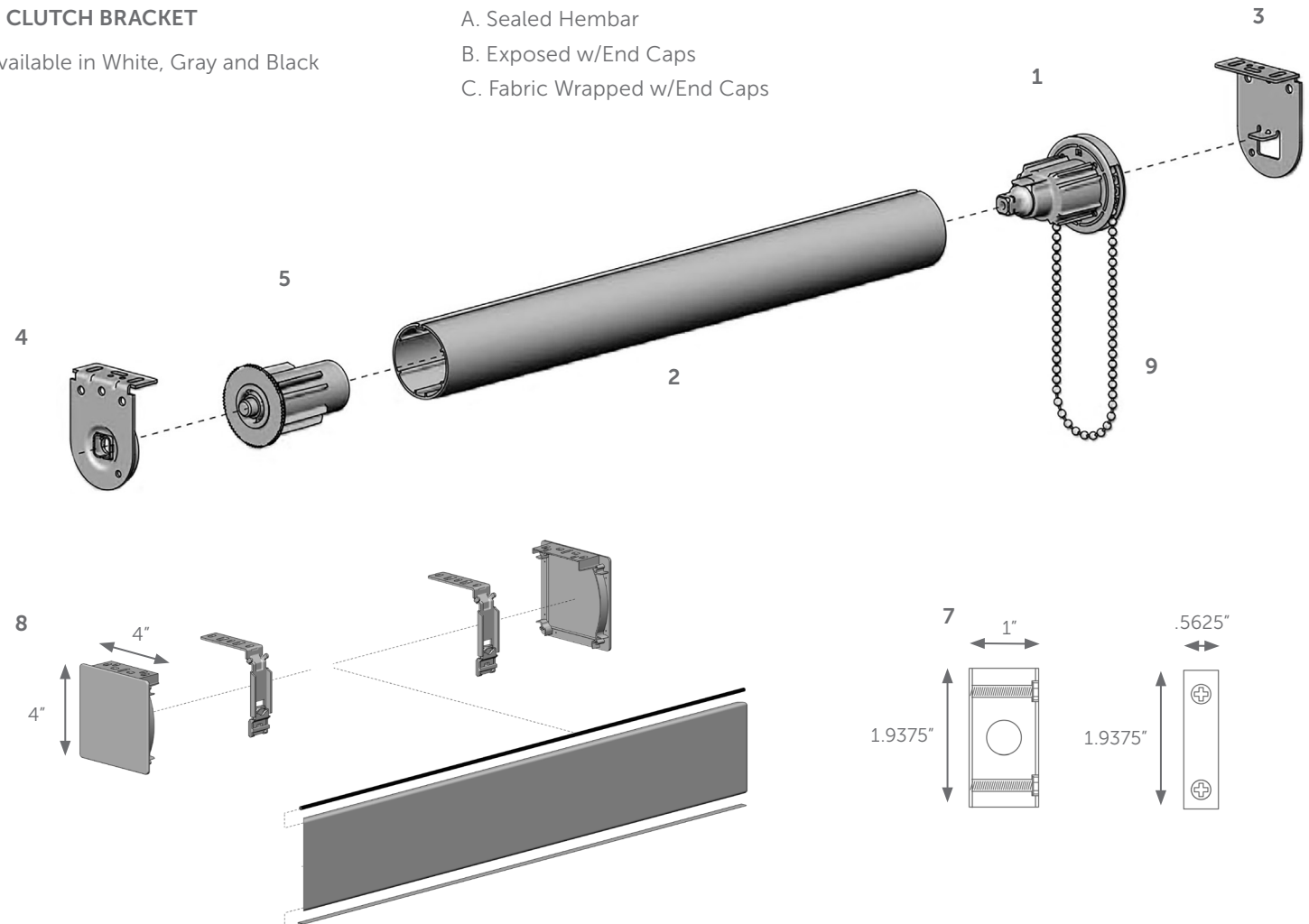

HEMBAR OPTIONS

# ML-40

## MANUAL TOP DOWN ROLLER SHADE WITH CLUTCH SYSTEM

### SHADE DEDUCTIONS

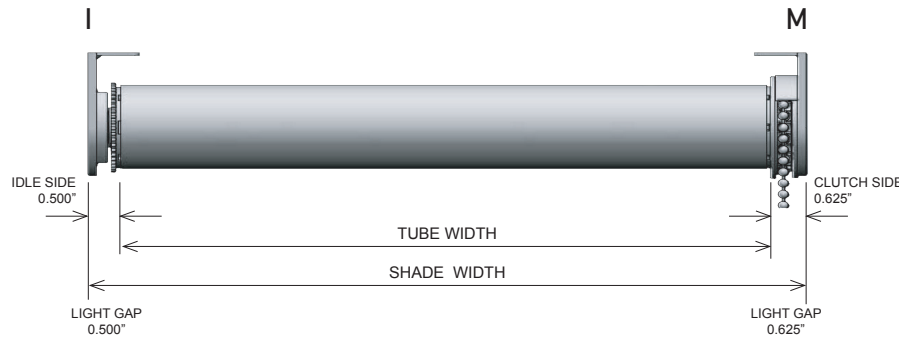

### COUPLED SHADE DEDUCTIONS

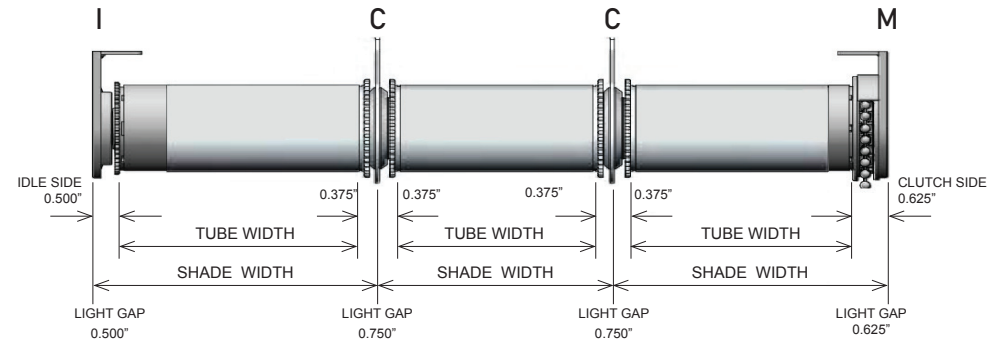

DRIVE	BRACKETS	IDLE SIDE	COUPLER SIDE	CLUTCH SIDE	OVERALL DEDUCTION
M-I	WITH FASCIA END CAPS	0.625" (15.9mm)		0.750" (19.1mm)	1.375" (34.9mm)
	WITHOUT FASCIA END CAPS	0.500" (12.7mm)		0.625" (15.9mm)	1.125" (28.6mm)
I-C	WITH FASCIA END CAPS	0.625" (15.9mm)	0.375" (9.5mm)		1.00" (25.4mm)
	WITHOUT FASCIA END CAPS	0.500" (12.7mm)	0.375" (9.5mm)		0.875" (22.2mm)
C-C	WITH FASCIA END CAPS		0.750" (19.1mm)		0.750" (19.1mm)
	WITHOUT FASCIA END CAPS		0.750" (19.1mm)		0.750" (19.1mm)
M-C	WITH FASCIA END CAPS		0.375" (9.5mm)	0.750" (19.1mm)	1.125" (28.6mm)
	WITHOUT FASCIA END CAPS		0.375" (9.5mm)	0.625" (15.9mm)	1.00" (25.4mm)

### ML-40 SYSTEM CAPACITY

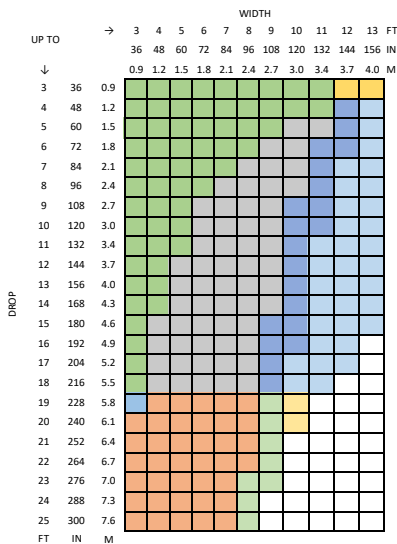

Parameters  
 Fabric Weight (oz/sq yd): 13.30  
 Fabric Thickness (in): 0.02  
 Hembar Weight (oz/ft): 2.75

CONTROL	BRACKET	TUBE
RB07/RB09 Clutch	VX Bracket	45mm
RB07/RB09 Clutch	LX Bracket	45mm
RB07/RB09 Clutch	VX Bracket	49mm
RB07/RB09 Clutch + Spring	VX Bracket	45mm
RB07/RB09 Clutch + Spring	LX Bracket	45mm
RB07/RB09 Clutch + Spring	VX Bracket	49mm
RB07/RB09 Clutch + Spring	LX Bracket	49mm
RB07/RB09 Clutch + Spring	VX Bracket	45/49mm VX Coupler
RB07/RB09 Clutch + Spring	LX Bracket	45/49mm LX Coupler

\*For optimal performance shades need to maintain 4:1 ratio of length to width. Shades can be outside this ratio however shade performance could be impacted  
 \*\*Exceeding these values may cause fabric tracking issues  
 \*\*\*Coupled shades are available for larger widths

### MAX ROLL

